

Micro 200 CCR

sinusoidal range of
constant current regulators





Control panel of the middle cabinet. It features a rotary knob on the left, a digital display on the right, and a yellow warning label. At the top, there are three indicator lights: a red one with a flame symbol, a green one, and a white one.

Control panel of the right cabinet. It features a rotary knob on the left, a digital display on the right, and a yellow warning label. At the top, there are four indicator lights: a red one with a flame symbol, a green one, a white one, and a white one with the text "FALT".

Technical specifications and safety instructions for the left cabinet.

Technical specifications and safety instructions for the middle cabinet.

Wohn-100 Control Tower Register
Produced in the UK
www.ajpinter.com
Tel: +44 (0)1223 441 111
Fax: +44 (0)1223 441 112
Email: sales@ajpinter.com
Address: 100, 101, 102, 103, 104, 105, 106, 107, 108, 109, 110, 111, 112, 113, 114, 115, 116, 117, 118, 119, 120, 121, 122, 123, 124, 125, 126, 127, 128, 129, 130, 131, 132, 133, 134, 135, 136, 137, 138, 139, 140, 141, 142, 143, 144, 145, 146, 147, 148, 149, 150, 151, 152, 153, 154, 155, 156, 157, 158, 159, 160, 161, 162, 163, 164, 165, 166, 167, 168, 169, 170, 171, 172, 173, 174, 175, 176, 177, 178, 179, 180, 181, 182, 183, 184, 185, 186, 187, 188, 189, 190, 191, 192, 193, 194, 195, 196, 197, 198, 199, 200, 201, 202, 203, 204, 205, 206, 207, 208, 209, 210, 211, 212, 213, 214, 215, 216, 217, 218, 219, 220, 221, 222, 223, 224, 225, 226, 227, 228, 229, 230, 231, 232, 233, 234, 235, 236, 237, 238, 239, 240, 241, 242, 243, 244, 245, 246, 247, 248, 249, 250, 251, 252, 253, 254, 255, 256, 257, 258, 259, 260, 261, 262, 263, 264, 265, 266, 267, 268, 269, 270, 271, 272, 273, 274, 275, 276, 277, 278, 279, 280, 281, 282, 283, 284, 285, 286, 287, 288, 289, 290, 291, 292, 293, 294, 295, 296, 297, 298, 299, 300, 301, 302, 303, 304, 305, 306, 307, 308, 309, 310, 311, 312, 313, 314, 315, 316, 317, 318, 319, 320, 321, 322, 323, 324, 325, 326, 327, 328, 329, 330, 331, 332, 333, 334, 335, 336, 337, 338, 339, 340, 341, 342, 343, 344, 345, 346, 347, 348, 349, 350, 351, 352, 353, 354, 355, 356, 357, 358, 359, 360, 361, 362, 363, 364, 365, 366, 367, 368, 369, 370, 371, 372, 373, 374, 375, 376, 377, 378, 379, 380, 381, 382, 383, 384, 385, 386, 387, 388, 389, 390, 391, 392, 393, 394, 395, 396, 397, 398, 399, 400, 401, 402, 403, 404, 405, 406, 407, 408, 409, 410, 411, 412, 413, 414, 415, 416, 417, 418, 419, 420, 421, 422, 423, 424, 425, 426, 427, 428, 429, 430, 431, 432, 433, 434, 435, 436, 437, 438, 439, 440, 441, 442, 443, 444, 445, 446, 447, 448, 449, 450, 451, 452, 453, 454, 455, 456, 457, 458, 459, 460, 461, 462, 463, 464, 465, 466, 467, 468, 469, 470, 471, 472, 473, 474, 475, 476, 477, 478, 479, 480, 481, 482, 483, 484, 485, 486, 487, 488, 489, 490, 491, 492, 493, 494, 495, 496, 497, 498, 499, 500, 501, 502, 503, 504, 505, 506, 507, 508, 509, 510, 511, 512, 513, 514, 515, 516, 517, 518, 519, 520, 521, 522, 523, 524, 525, 526, 527, 528, 529, 530, 531, 532, 533, 534, 535, 536, 537, 538, 539, 540, 541, 542, 543, 544, 545, 546, 547, 548, 549, 550, 551, 552, 553, 554, 555, 556, 557, 558, 559, 560, 561, 562, 563, 564, 565, 566, 567, 568, 569, 570, 571, 572, 573, 574, 575, 576, 577, 578, 579, 580, 581, 582, 583, 584, 585, 586, 587, 588, 589, 590, 591, 592, 593, 594, 595, 596, 597, 598, 599, 600, 601, 602, 603, 604, 605, 606, 607, 608, 609, 610, 611, 612, 613, 614, 615, 616, 617, 618, 619, 620, 621, 622, 623, 624, 625, 626, 627, 628, 629, 630, 631, 632, 633, 634, 635, 636, 637, 638, 639, 640, 641, 642, 643, 644, 645, 646, 647, 648, 649, 650, 651, 652, 653, 654, 655, 656, 657, 658, 659, 660, 661, 662, 663, 664, 665, 666, 667, 668, 669, 670, 671, 672, 673, 674, 675, 676, 677, 678, 679, 680, 681, 682, 683, 684, 685, 686, 687, 688, 689, 690, 691, 692, 693, 694, 695, 696, 697, 698, 699, 700, 701, 702, 703, 704, 705, 706, 707, 708, 709, 710, 711, 712, 713, 714, 715, 716, 717, 718, 719, 720, 721, 722, 723, 724, 725, 726, 727, 728, 729, 730, 731, 732, 733, 734, 735, 736, 737, 738, 739, 740, 741, 742, 743, 744, 745, 746, 747, 748, 749, 750, 751, 752, 753, 754, 755, 756, 757, 758, 759, 760, 761, 762, 763, 764, 765, 766, 767, 768, 769, 770, 771, 772, 773, 774, 775, 776, 777, 778, 779, 780, 781, 782, 783, 784, 785, 786, 787, 788, 789, 790, 791, 792, 793, 794, 795, 796, 797, 798, 799, 800, 801, 802, 803, 804, 805, 806, 807, 808, 809, 810, 811, 812, 813, 814, 815, 816, 817, 818, 819, 820, 821, 822, 823, 824, 825, 826, 827, 828, 829, 830, 831, 832, 833, 834, 835, 836, 837, 838, 839, 840, 841, 842, 843, 844, 845, 846, 847, 848, 849, 850, 851, 852, 853, 854, 855, 856, 857, 858, 859, 860, 861, 862, 863, 864, 865, 866, 867, 868, 869, 870, 871, 872, 873, 874, 875, 876, 877, 878, 879, 880, 881, 882, 883, 884, 885, 886, 887, 888, 889, 890, 891, 892, 893, 894, 895, 896, 897, 898, 899, 900, 901, 902, 903, 904, 905, 906, 907, 908, 909, 910, 911, 912, 913, 914, 915, 916, 917, 918, 919, 920, 921, 922, 923, 924, 925, 926, 927, 928, 929, 930, 931, 932, 933, 934, 935, 936, 937, 938, 939, 940, 941, 942, 943, 944, 945, 946, 947, 948, 949, 950, 951, 952, 953, 954, 955, 956, 957, 958, 959, 960, 961, 962, 963, 964, 965, 966, 967, 968, 969, 970, 971, 972, 973, 974, 975, 976, 977, 978, 979, 980, 981, 982, 983, 984, 985, 986, 987, 988, 989, 990, 991, 992, 993, 994, 995, 996, 997, 998, 999, 1000



Introduction

The atg airports Micro 200 CCR is specifically designed to provide a sinusoidal wave form power source to lighting circuits containing both LED and conventional lighting fixtures plus other electronic devices.

The Micro 200 is fitted with state of the art electronics that monitor and adjust the output waveform many thousands of times per second to produce a sinuwave output. This leads to superior responses to load changes and circuit switching, improved protection against overcurrent or open circuit fault conditions whilst delivering superior power factors without compromising on a minimised harmonic content.

Features

- The atg airports Micro 200 CCR employs Pulse Width Modulation (PWM) Control of an IGBT H bridge to produce a sinusoidal output current wave form and near unity power factor at all brilliancy levels
- Delivers a substantial improvement in the harmonic content of the supply current
- Uses the same cubicle footprint as previous designs, which keeps floor space requirements to a minimum
- monitoring and diagnostic information to be presented to Engineers and Technicians. This can include:
 - Output Current Value
 - Brightness Step
 - % of Maximum Output
 - Alarm Text Description
 - Number of Failed Lamps
 - Hours Run Counter
 - Insulation reading
 - Power analysis
- Micro-controlled Display allowing extensive CCR

Compliance and approval with standards

- ICAO Aerodrome Design Manual, Part 5
- UK CAP 168
- FAA AC No: 150/5345-10F
- IEC 61822:2003
- EN 61000-6-2:2005
- EN 61000-6-4:2001

Standard functions and displays

- Sine Wave Output at all brilliances on resistive loads
- Active Control to maintain performance on non-linear loads
- Near Unity Power factor at all brilliancy levels
- Display of true output current RMS value
- Open Circuit Protection
- Short Circuit Protection
- Monitoring of Current intolerance
- Output VA drop error
- Dual Hours Run Counter records of runtime at maximum brilliancy and total hours run time at any brilliancy level
- Near instantaneous reaction to current overloads during block switching operations
- Internal/External brilliancy control
- CCR “On” - current flowing in the series loop
- Warning indication of “Open Circuit”, “Over Current”, and “Output Current Tolerance Fault”
- Elapsed time hours counter at maximum brilliancy
- Elapsed time hours counter of total hours run
- Built-in adjustable current ramp for switch on, enhances lamp life by reducing stress on lamp filaments
- Parameters configurable from front panel
- Castors for easy manoeuvrability
- Eye bolts for easy lifting
- Built in 24/48V supply for control systems
- Contained in Vermin proof powder coated cabinet

Optional functions and displays

- Display of series circuit leakage resistance value
- Internal lightning arrestors on the outgoing circuit
- Lamp Failure Detection – displayed as a total number of lamps failed, or as a percentage of total lamps. Accuracy ± 1 lamp for up to 10 faults and ± 3 for up to 30 lamps at all brilliancy steps
- Earth Leakage Detection – measures the insulation resistance of the series circuit. Two stage alarm output available
- Serial Communication Remote Control – serial communication is available through the micro-controller. It is available in two versions, single and dual and communicates with hardware using RS485 and modern protocols such as J-Bus and PROFIBUS. The dual version gives the control system enhanced redundancy up to the CCR
- Plug-in, HV Cut Out Switch – An additional safety device can be fitted that isolates the series circuit from the CCR output. It also provides earthing facilities for the series circuit and insulation resistance measuring point
- Circuit selector switches integral to the CCR
- Power Monitor to display output voltage (RMS value), input power factor, input voltage, efficiency, circuit power (kW/kVA)

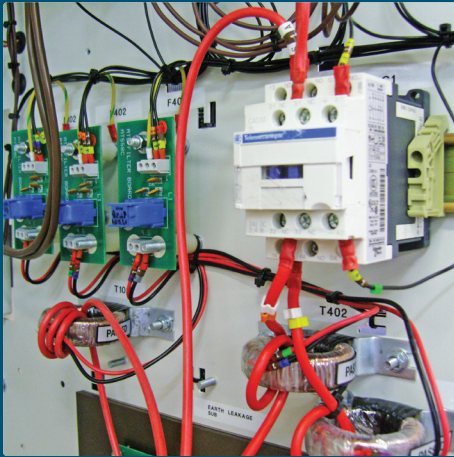

Design

The atg airports Micro 200 CCR is a microprocessor supervised Constant Current Regulator with the current control loop and H bridge output and protection circuitry realised in high speed analogue electronics.

Each atg Micro 200 CCR is in a self contained cubicle divided into four main compartments separating HV, LV and control elements.

Microcontroller and display compartment

This compartment comprises a PCB Sub-assembly using a microcontroller to allow parameterisation of the CCR characteristics and display of monitored and alarm information. All of the electronic sub-assemblies in this section are accessible from the front of the CCR cubicle.

Analogue electronics

This compartment includes the main control PCB associated with the feedback controller, error amplifier, H-bridge controller, lamp failure detection and earth fault detection. In this section components are accessible from the front of the CCR cubicle.

Power

These compartments contain all the power components connected to the CCR output current loop such as the IGBT stack, H-bridge and power control card, main contactor, main transformer, feedback transformers, filters and transformer terminals. These sections are accessible from both the side and rear of the CCR cubicle.

Connection

Mains Supply Input

This compartment allows for the connection to input terminals and access to fuses, without the need to access the power compartment. It is accessible at the rear of the cubicle.

Control Connections

HT Output Terminal

Contains up to 7 output terminals, optional lighting arrestors and a HV cut out switch.

Technical Specification

Power factor

Close to unity at maximum brilliancy and better than 0.9 at minimum when connected to a rated load.

Efficiency

At nominal power into a resistive load, nominal voltage and maximum brilliancy.

- Better than 90%

Output power ratings

- At 210, 220, 230, 240V:
Outputs of 1.5, 2.5, 4.0, 5.0, 7.5 kVA
- At 380, 400, 415V:
Outputs of 2.5, 4.0, 5.0, 7.5, 10.0, 12, 15 kVA

Output current ratings

- 6.0A, 6.6A, 12A

Input voltage ratings

- 220, 230, 240V Single Phase 50/60 Hz
- 380, 400 & 415V Single Phase, 50/60Hz

Remote Control

- Digital 24 or 48 VDC (8 wire and command)
- Analogue
- 3 wire and command
- BCD and command
- Serial communication (optional) RS485 Protocols.

Operating environmental conditions

- From short circuit to full load
- For nominal input voltage $\pm 10\%$
- For ambient temperatures from -40°C to $+50^{\circ}\text{C}$
- For altitudes up to 2000m
- For a relative humidity range of 10% RH to 95% RH
- Maximum 30% of transformers open circuit in their secondary

Protection devices

Protection against "Open Circuit" is activated when the output current falls below 1 amp for more than 100ms
Protection against "Over Current" is activated when:

IEC Settings

- The current reaches 102.5 % of nominal value for more than 5s
- Or the current reaches 125% of nominal value for more than 300ms

FAA Settings

- The current reaches 105% of nominal value for more than 5s
- Or the current reaches 125% of nominal value for more than 1s

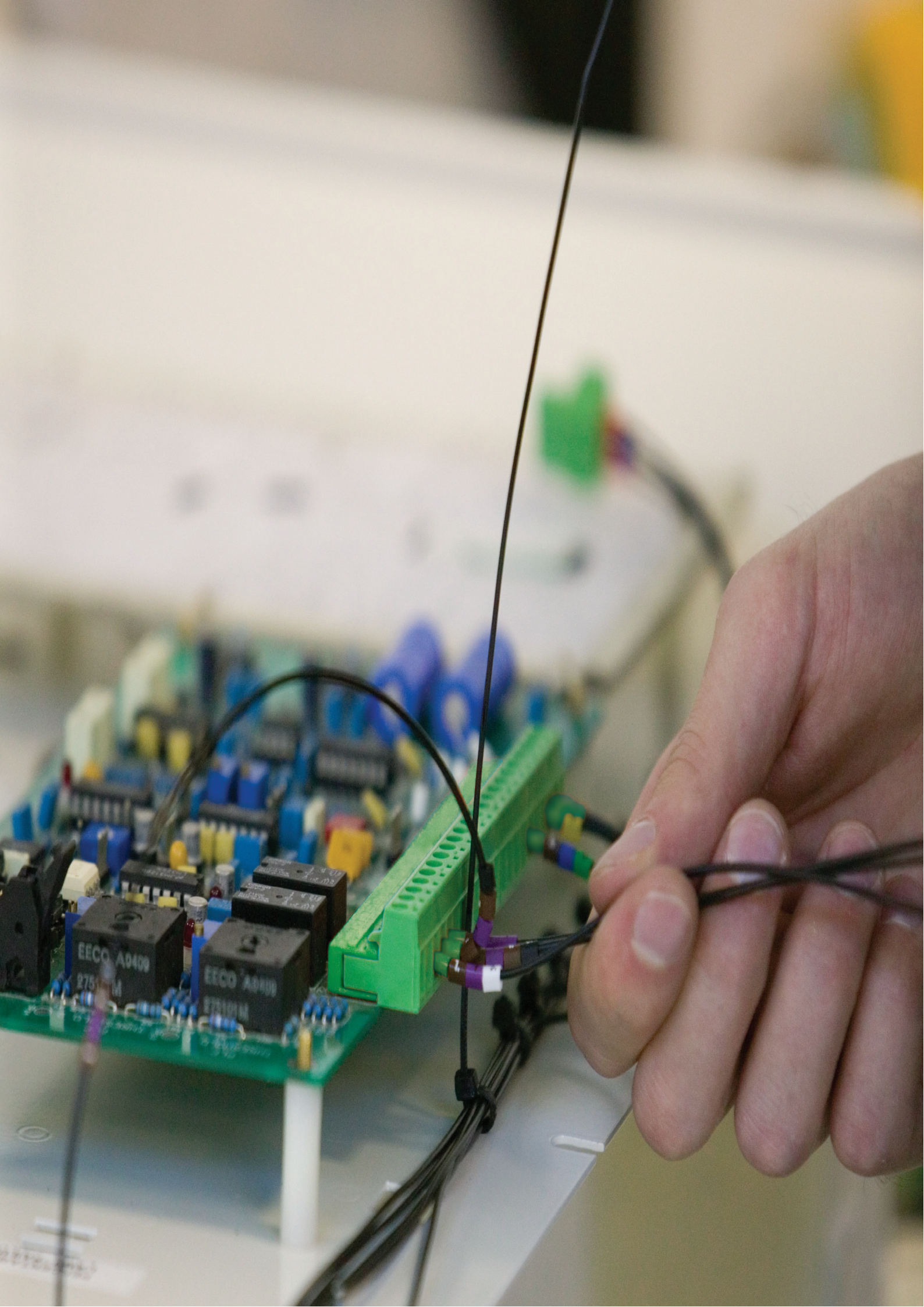

Front panel

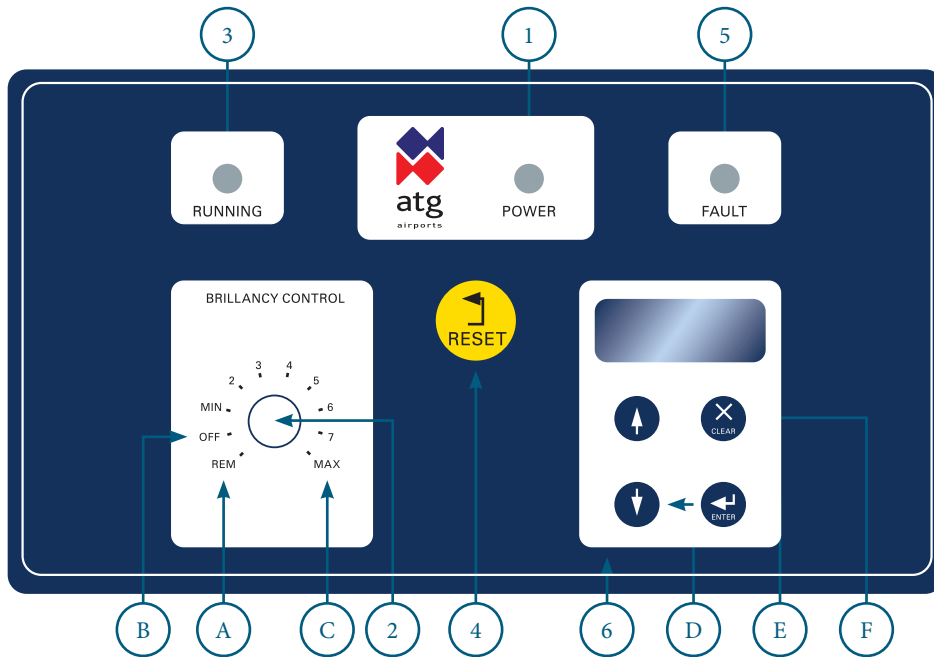

- | | | |
|---------------------------|-----------------------|----------------|
| 1 CCR Power 'ON' | 4 Fault Reset Button | Buttons |
| 2 Selection Rotary Switch | 5 CCR Fault Indicator | E Enter/Accept |
| A Remote Mode | 6 Alpha - Numeric | F Cancel |
| B Off | Fault/Status Display | |
| C Brilliancy Levels | D Scroll Up/Down | |
| 3 CCR "Running" | | |

* Note Rotary switch notation/operation can be changed to suit clients existing systems.

Block diagram

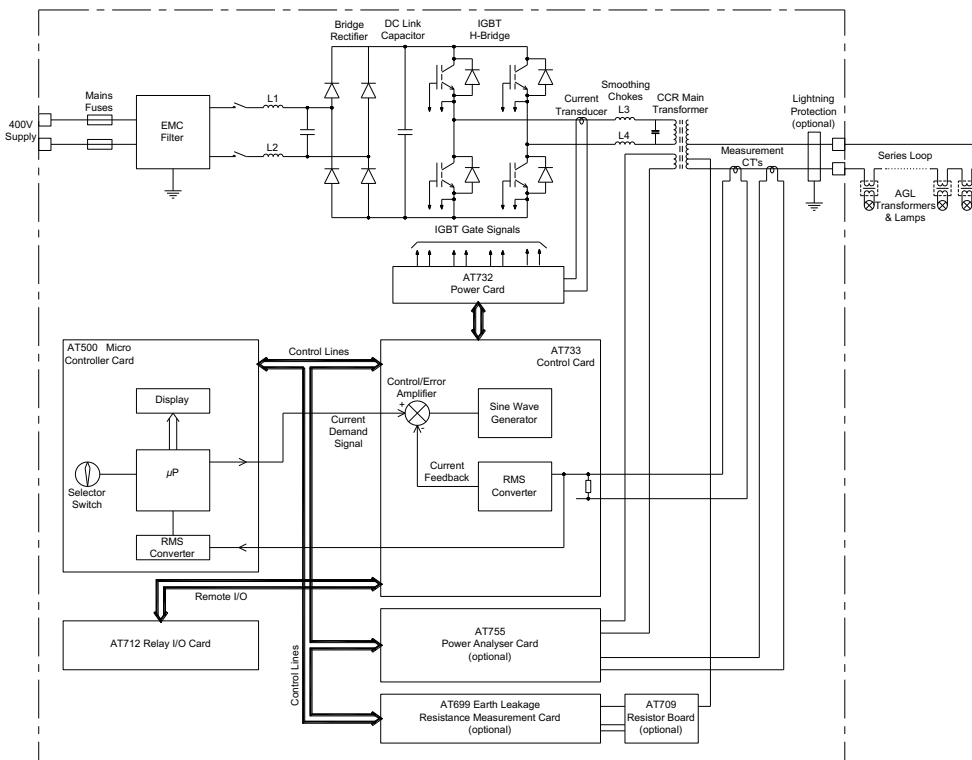

Suggested specification

The Constant Current Regulator shall be microprocessor assisted using high speed IGBT technology to control the input to the main transformer to produce a sinusoidal output waveform. It shall comply with IEC 61822 and ICAO Aerodrome Design

Manual Part 5, para 3.2.1.4 to 3.2.16 or FAA specs L-829/L828 in Advisory Circular AC 150/5345-10F.

The CCR should be designed for continuous indoor operation in an ambient temperature of -40°C to $+50^{\circ}\text{C}$ and maximum relative humidity of 95%.

The CCR shall have a regulation accuracy of $\pm 1\%$ of values of intensity under the following conditions:

- Load Variation between 0% and 100%
- Supply Voltage Variation $+10\%$ to 20%
- Supply Frequency Variation $\pm 5\%$
- Power Factor 0.9 efficiency greater than 0.9 at full load

The CCR will contain a series circuit transformer with multiple tappings on the secondary winding delivering variable power from the CCR output and to adjust the CCR capacity to actual load, improving the primary power factor and efficiency of the Micro 200 CCR. The CCR should be equipped with the following features:

- Open circuit protection device
- Over current protection device
- Current monitoring and display
- Lamp failure detection (option)
- Internal lightning arrestors on the output circuit (option)
- Elapsed time recording
- Brightness control: up to 8 steps
- Adjustable operating parameters accessed via the CCR front panel
- Remote monitoring via volt free contacts
- Tolerance monitoring (difference between actual and set brilliancy level)
- Insulation resistance monitoring (option)

The CCR may also be supplied with the following optional equipment:

- Serial Communications Interface (MODBUS, JBUS, PROFIBUS)
- Series Circuit insulation resistance measurement using 500 VDC test voltage when CCR is operating or manual test at 1000 VDC
- Integral Circuit Selector Unit (2,3,4,5 or 6 way)





Head Office:
atg airports ltd
Lowton Business Park | Newton Road
Lowton St. Mary's | Warrington
WA3 2AP | United Kingdom

 UK: +44 (0) 1942 68 5555 | USA: 001 (239) 985-9406

 www.atgairports.com

 enquiries@atgairports.com

 sales-usa@atgairports.com